

# L-950

## GENERATION 2

LeTourneau  
MINING  
PRODUCTS



<b>ENGINE</b>	1050 hp	783 kW
<b>PAYLOAD</b>		
<b>STANDARD</b>	54000 lb	24494 kg
<b>HIGH LIFT</b>	48000 lb	21773 kg
<b>BUCKET CAPACITY</b>	sized to material density	
<b>TRUCK MATCH</b>	75 - 120 ton	68 - 109 tonne



## POWER MODULE

### DIESEL POWER OPTIONS

#### MTU DETROIT DIESEL ENGINE

Model	Tier Two 16V Series 2000 16 cylinders
Type	4-cycle turbocharged
Rated Power	1050 hp (783 kW) @ 1800 rpm

#### CUMMINS DIESEL ENGINE

Standard Model	Tier Two QST 30 12 cylinders
Type	4-cycle turbocharged
Rated Power	1050 hp (783 kW) @ 1800 rpm

The independent power module mounting system, consisting of the engine coupled to the SR generator, is cradled within the rear frame by a three-point isolation system.

#### RADIATOR/OIL COOLER MODULE

- Replaceable tube type, side-by-side split flow
- Thermostatically controlled, variable speed hydraulic motor-driven, radiator-mounted fan
- Auxiliary oil cooler available for high ambient conditions

#### EXHAUST SYSTEM

Dual low restriction mufflers with vertical, mid-hood discharge

## AIR FILTRATION

#### PRIMARY

- LeTourneau Self Cleaning KLENZ™ Filtration System  
99.9% Efficiency Removing to 0.3 Microns (nominal)
- Extends maintenance intervals
  - Filtered air for engine, drive system cooling and pressurized cab

#### SECONDARY

Dual safety filters for engine

## CONTROL SYSTEM-LINCS II™

#### LETOURNEAU INTEGRATED NETWORK CONTROL SYSTEM-LINCS II™

Next generation microprocessor based modular design Vehicle Control Unit with monitoring and diagnostics including integrated data logging and storage.

LINCS II™ uses a dash mounted full color touch screen display as the operator interface. Out of range conditions will cause an audible alarm along with a message screen that is color coded to indicate severity.

In addition, the touch-screen display provides repair technicians with operational data and fault messages.

#### LINCS II™ LOAD WEIGH

- Displays real-time load per pass, per truck and total loads
- Memory capable of retaining months of production information
  - Capable of interfacing with radio dispatch systems for real-time monitoring

## PROPULSION SYSTEM

LeTourneau Switched Reluctance (SR) Hybrid Technology Propulsion System

- Digital microprocessor controlled traction drive
- Switched Reluctance (SR) drive advantages include:
  - No commutator, brushes or rotor windings on SR motors or generator
  - Hybrid regenerative energy storage for improved fuel economy
  - Parts commonality - power conversion module identical for motor and generator

#### TRAVEL SPEED

Forward and reverse 0-12 mph (0-19.31 km/h)

#### GENERATOR

- LeTourneau G100 SR generator
- Switched Reluctance (SR)

#### TRACTION MOTORS

- LeTourneau B40A SR motor
- SR all wheel drive (independent SR motor for each wheel)

#### DRIVE GEARING

- |       |                |
|-------|----------------|
| Model | LeTourneau 35A |
|-------|----------------|
- In-line gear train mounted within the rim of the tire, transmitting power from the traction motor through the tire/rim assembly.
  - A four-stage planetary drive unit in each position
  - Total reduction 96:1

## BRAKING SYSTEM

#### PRIMARY BRAKE SYSTEM

Electric dynamic braking system is controlled from the accelerator pedal and can bring the loader to a full stop without application of mechanical brakes.

#### SECONDARY BRAKE SYSTEM

- Air modulated traction motor speed disc brakes
- Single disc and caliper on each traction motor
  - Emergency fail safe brakes are spring applied in the event of air pressure loss

#### PARKING BRAKE SYSTEM

Spring applied, air release traction motor speed disc brakes

## STEERING AND HOISTING SYSTEM

#### STEERING

Steering function is controlled by a single joystick. LeTourneau's constant engine rpm assures full hydraulic steering response.

- |                      |            |         |
|----------------------|------------|---------|
| • Articulation angle | 42°        |         |
| • Turning Radius     |            |         |
| • Standard Lift      | 33 ft 9 in | 10.29 m |
| • High Lift          | 34 ft 6 in | 10.52 m |

#### HOIST AND BUCKET CONTROL

Hoist and bucket control functions are incorporated into a single joystick control. The proportional electro-hydraulic controlled hoist and bucket system is independent of the steering system.

Standard/High Lift Cycle Times:

Hoist	11 Seconds
Dump	2 Seconds
Float	5 Seconds



## HYDRAULIC SYSTEM

### HPD DRIVE BOX

- Wet spline design with pressurized, cooled, and filtered lubrication
- Ratio 1:1

### PUMPS (Maximum flow rate at 1,800 rpm)

Main	Piston (2)	247 gpm	936 L/min
Steering	Piston	108 gpm	407 L/min
Fan/Blower Drive	Piston	45/45 gpm	171/171 L/min
Accessory	Piston	21 gpm	81 L/min
Cooling System			
Circulating Pump	Vane	108 gpm	407 L/min
Aux. Cooling (optional)	Piston	17 gpm	64 L/min

### VALVES

Main	Three (3)	175 gpm	663 L/min
	Pump Pressure	3700 psi	25510 kPa
Steering	One (1)	90 gpm	341 L/min
	Pump Pressure	3400 psi	23443 kPa

### CYLINDERS

Double-acting, single-stage (diameter and stroke), (standard and high lift)

• Hoist	10 in x 64.5 in	254 mm x 1638 mm
• Bucket	10 in x 25.5 in	254 mm x 648 mm
• Steering	7.5 in x 30 in	190 mm x 762 mm

## STRUCTURAL

LeTourneau frames are fabricated from high strength, low-alloy steel with excellent weld characteristics and extreme low temperature properties. The front axle is an integral, fixed part of the front frame. The rear axle center oscillates 11 degrees.

Unique LeTourneau forged ball and socket joints are utilized in multiple pivot locations (lift arms, rear axle, frame articulation, hoist cylinders). These joints are superior in absorbing and distributing multi-directional stresses. Features easily replaceable brass liners for long life and easy maintenance.

High strength castings are used in key areas of fabricated structures to reduce stress and improve structural life.

## STANDARD FEATURES

### TIRES/RIMS

- Tires 45/65-45 L-5
- Rims 36 x 45 with 4.5" flange

### STANDARD EQUIPMENT

- Access Ladder Lights
- Air Clean-Out Hose In Cab
- Air Conditioning / Heater-Defroster (Filtered and Pressurized)
- Air Dryer System
- Air Horn
- Air Tank Bleed System
- Adjustable Automatic Lift Height Cut Off
- Automatic Bucket Leveling Control
- Automatic Electrical Cabinet Lights
- Automatic Lubrication System
- Back-up Alarm, Audible
- Battery Disconnect Switch
- Brake Lights
- Central Air Regulator Box
- Data Analysis and Viewing Software
- Data Logging - Downloadable Production and Maintenance Logs
- Door Interlock on Electrical Cabinet
- Drawbar with tow points
- Emergency Stop Buttons (Cab and Remote Mounted)

- Engine Compartment Lights
- Fire Extinguisher, Manual, 20 lb (9.07 kg)
- FOPS - Falling Object Protection System
- Idle Timer
- Interior Lights
- Isolation Monitor
- Joystick Hoist and Bucket Control
- Joystick Steering Control
- Jump Start
- Ladder Walkway (Rear Access)
- LED Working Lights (10 Forward, 2 Rear)
- LINC'S II™ Alarms
- LINC'S II™ Load Weigh & Monitoring
- Mirrors, Rearview (Parabolic)(2)
- Operator Seat (11-Way Adjustable)
- Overspeed Alarm
- Parking Brake
- Retractable Lap Belt with Shoulder Harness
- Rock Deflectors (Bucket)
- ROPS - Rollover Protection Structure
- Selectable Throttle Switch
- Starter Disconnect Switch
- Sun Visor
- Tinted Safety Glass Throughout
- Turn Signals
- Twelve (12) Volt Power Supply In Cab
- Twelve (12) Volt Power Port (2)
- Walk Around Catwalk for Cab
- Windshield Washer Reservoir (2.6 gal)
- Windshield Wiper and Washer (Front & Rear)

## OPTIONAL FEATURES

- Auxiliary Hydraulic Oil Cooler
- Auxiliary Steering
- Beacon Light Kit
- Bucket GET Options Available
- Central Service with Fast Fuel
- Cold Weather Package- including:
  - Battery Heater
  - Engine Heating System (Oil and Water)
  - Grease Reservoir Heater
  - Hydraulic Tank Heater
- Fast Fuel
- Fire Detection and Suppression System (Manual)
- Fire Suppression System (Manual)
- Fluid Sampling Kit
- Lift Arms - High Lift
- Training Seat (with Lap Belt)
- Video Camera (Rear Mount)

## BUCKETS

STANDARD, ISO-RATED CAPACITY:

54000 lb / 24494 kg

HIGH LIFT, ISO-RATED CAPACITY:

48000 lb / 21773 kg

Both rock and coal bucket configurations are available  
Buckets sized to material density

## BUCKET HARDWARE OPTIONS

- Skid Plates (Replaceable)
- Lip Wear Protection
- Wear Liner Kits

For actual bucket configuration and sizing, consult your dealer representative.

# OPERATING CAPACITIES, WEIGHTS AND DIMENSIONS

	STANDARD LIFT		HIGH LIFT	
	18 yd <sup>3</sup>	13.76 m <sup>3</sup>	16 yd <sup>3</sup>	12.23 m <sup>3</sup>
Bucket Capacity**	54000 lb	24494 kg	48000 lb	21773 kg
Operating Payload	153000 lb	69400 kg	148000 lb	67132 kg
Static Tipping Loads	Straight	135000 lb	131000 lb	59421 kg
	Full 42° Turn	61236 kg	734 kN	
Breakout Force	160000 lb	712 kN	165000 lb	734 kN
Operating Weight	236500 lb	107275 kg	241500 lb	109544 kg

\*\* Standard Rock Bucket based on a material density of 3000 lb/yd<sup>3</sup> (1780 kg/m<sup>3</sup>)

## FLUID CAPACITIES

Fuel	630 gal	2384 L
Hydraulic	260 gal	984 L
SR Converter Cooling System	30 gal	114 L
Engine Cooling System	88 gal	333 L
Crankcase (includes filters)	Detroit	25 gal
	Cummins	23 gal
		87 L
Gearbox	5 gal	19 L
Drivers (each)	6.1 gal	23 L

## OPERATING DIMENSIONS

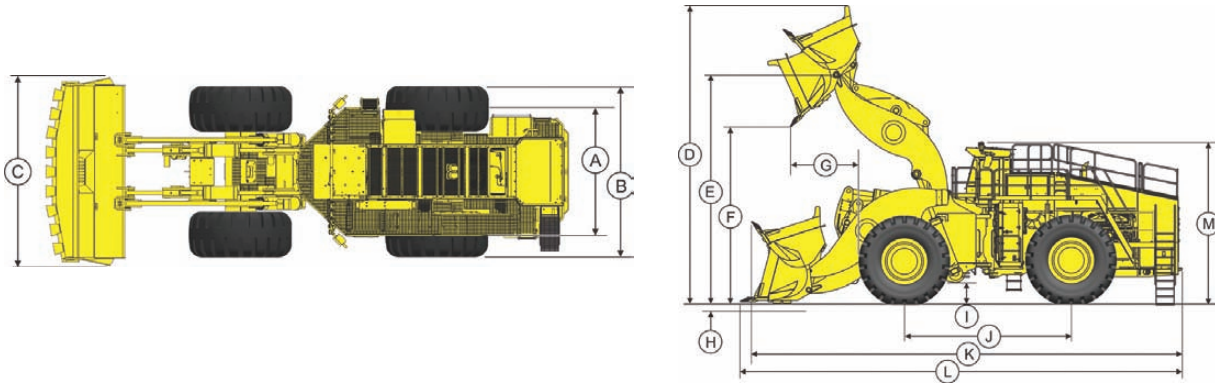

		STANDARD LIFT		HIGH LIFT	
(A)	Tread	12 ft 7 in	3.84 m	12 ft 7 in	3.84 m
(B)	Width Outside Tires	16 ft 4 in	4.98 m	16 ft 4 in	4.98 m
(C1)	Rock Bucket Without Deflectors	16 ft 7 in	5.06 m	16 ft 7 in	5.06 m
(C2)	Rock Bucket With Deflectors	17 ft 10 in	5.44 m	17 ft 10 in	5.44 m
(C3)	Coal Bucket	21 ft 0 in	6.40 m	21 ft 0 in	6.40 m
(D)	Height Bucket Fully Raised	30 ft 3 in	9.21 m	31 ft 8 in	9.65 m
(E)	Hinge – Pin Height	22 ft 8 in	6.91 m	24 ft 5 in	7.44 m
(F)	Dump Clearance	15 ft 1 in	4.60 m	17 ft 3 in	5.26 m
(G)	Reach at Full Lift	7 ft 9 in	2.37 m	7 ft 9 in	2.37 m
(H)	Digging Depth	0 ft 9 in	0.23 m	0 ft 9 in	0.23 m
(I)	Ground Clearance	1 ft 10 in	0.56 m	1 ft 10 in	0.56 m
(J)	Wheelbase	20 ft 2 in	6.15 m	20 ft 2 in	6.15 m
(K)	Overall Length Carry Position	50 ft 1 in	15.27 m	51 ft 11 in	15.82 m
(L)	Overall Length Bucket Down	51 ft 2 in	15.66 m	52 ft 3 in	15.92 m
(M)	Height Over Cab	18 ft 6 in	5.64 m	18 ft 6 in	5.64 m

\* All dimensions are based on standard tires and standard rock bucket with GET unless otherwise noted.

# LeTourneau

MINING PRODUCTS

P.O. Box 2307 • Longview, TX 75606 • phone (903) 237-7000 • fax (903) 236-6552 • [www.letourneutechnologies.com](http://www.letourneutechnologies.com)

Meets the following SAE and ISO Standards:

Braking Systems of Rubber Tired Machines SAE J/ISO 3450 • Loader Buckets Volumetric Ratings ISO 7546 • Sound Measurement Off Road Work Machines - Exterior SAE J 88

Earth Moving Machinery FOPS ISO 3449 • Sound Measurement Off Road Work Machines - Operator SAE J 919 • Rated Operating Load for Loaders SAE J 818

Earth Moving Machinery ROPS ISO 3471 • Earth Moving Machinery Steering Requirements ISO 5010

Please Note: Standard/Optional Equipment, Features and Performance conform to U.S. and International Standards as Required. LeTourneau Technologies, Inc. has made every effort to make these specifications as accurate as possible at the time of printing. However, we reserve the right to make changes and improvements at any time without notice, in equipment, materials and specifications. To ensure the most current information, please contact your dealer representative.

LeTourneau and LINC'S are registered trademarks of LeTourneau Technologies, Inc. ©2011

REV002-072011